

THIS DRAWING IS UNPUBLISHED. RELEASED FOR PUBLICATION
 © COPYRIGHT BY TYCO ELECTRONICS CORPORATION. ALL RIGHTS RESERVED.

LOC	DIST	REVISIONS			
P	LTR	DESCRIPTION	DATE	DWN	APVD
AF	50	S1	ECR-06-023927(REDRAWN IN AUTOCAD)	06OCT06	HMR GP

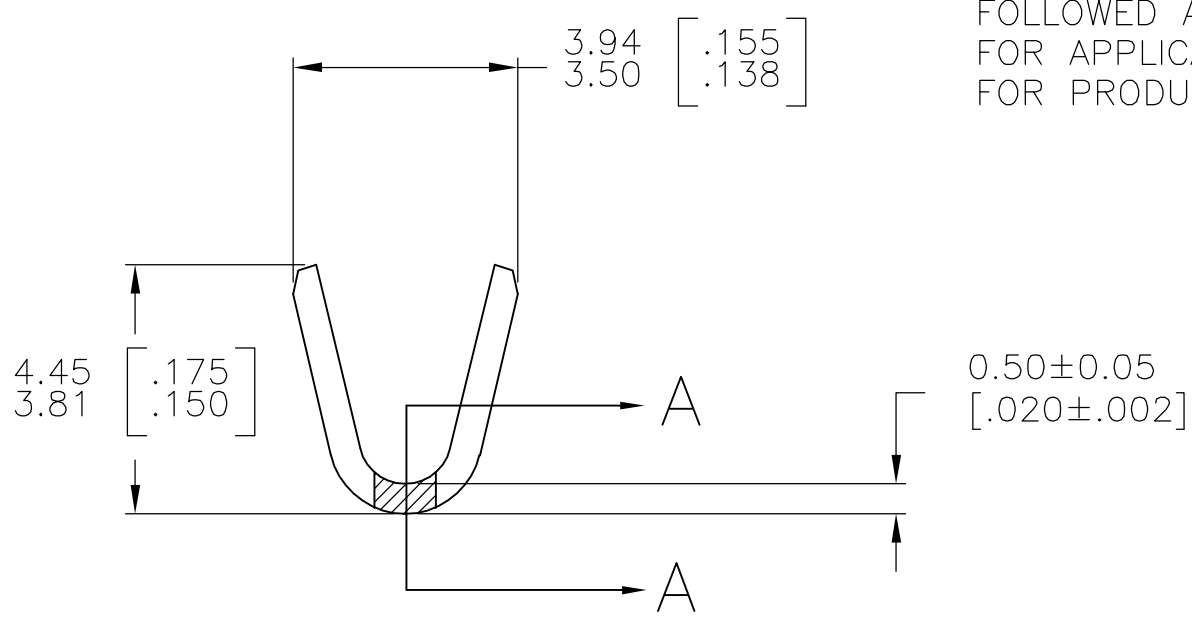

- 1 CONTINUOUS STRIP ON REELS.
- 2 DIMENSIONS IN BRACKETS ARE IN INCHES.
- 3 FOR ADDITIONAL INFORMATION, SEE APPLICATION SPEC. 114-2009.
- 4 Δ CRIMP WIDTH: .110 F TYPE (AMPLIVAR THRU)
 CRIMP HEIGHT ($\pm.002$)=(TOTAL CMA+10,700)/193,400
 GENERAL APPLICATION GUIDELINES MUST BE FOLLOWED AS SPECIFIED IN CATALOG #82221
 FOR APPLICATOR INFORMATION CALL:1-800-722-1111
 FOR PRODUCT INFORMATION CALL:1-800-522-6752

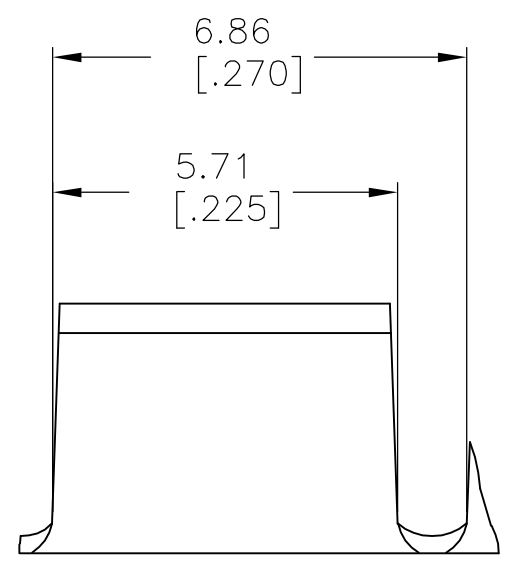
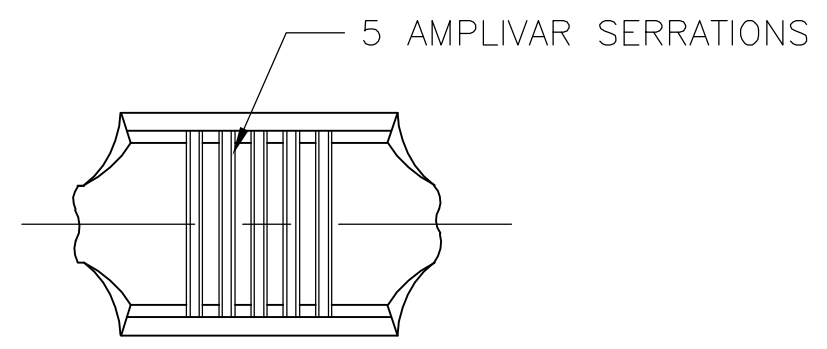
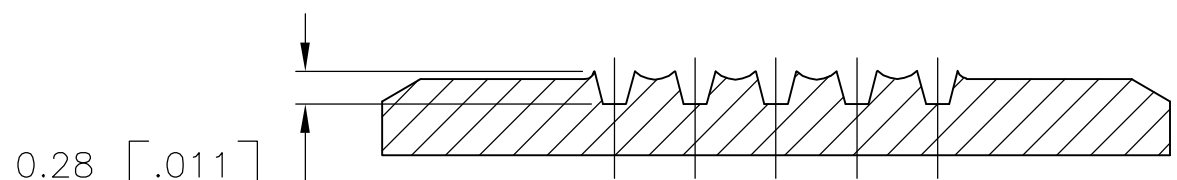

SECTION A-A
SCALE 20:1

OBSOLETE	1500-5000 CMA Δ 4	NICKEL FLASH	41765-1
	1500-5000 CMA Δ 4	-	41765
	WIRE RANGE	FINISH	PART NO

THIS DRAWING IS A CONTROLLED DOCUMENT.		DWN RAGHAVENDRA 06OCT06	Tyco Electronics Corporation Harrisburg, PA 17105-3608	
DIMENSIONS: mm [INCHES]		CHK G.D.PORTA	NAME	
TOLERANCES UNLESS OTHERWISE SPECIFIED:		APVD G.D.PORTA	PRODUCT SPEC	
0 PLC ± - 1 PLC ± - 2 PLC ± - 3 PLC ± 0.38 [.015] 4 PLC ± - ANGLES ± 1° 0'		APPLICATION SPEC		SPLICE, AMPLIVAR
MATERIAL BRASS	FINISH SEE TABLE	WEIGHT -	SIZE A3	CAGE CODE 00779
		DRAWING NO C-41765		RESTRICTED TO -
CUSTOMER DRAWING		SCALE 8:1	SHEET 1 OF 1	REV S1